

1





Rollatorbox, komplett

erweiterbar für Anbausatz mit
oder ohne Seitenwand

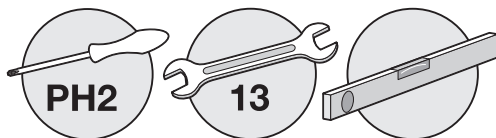
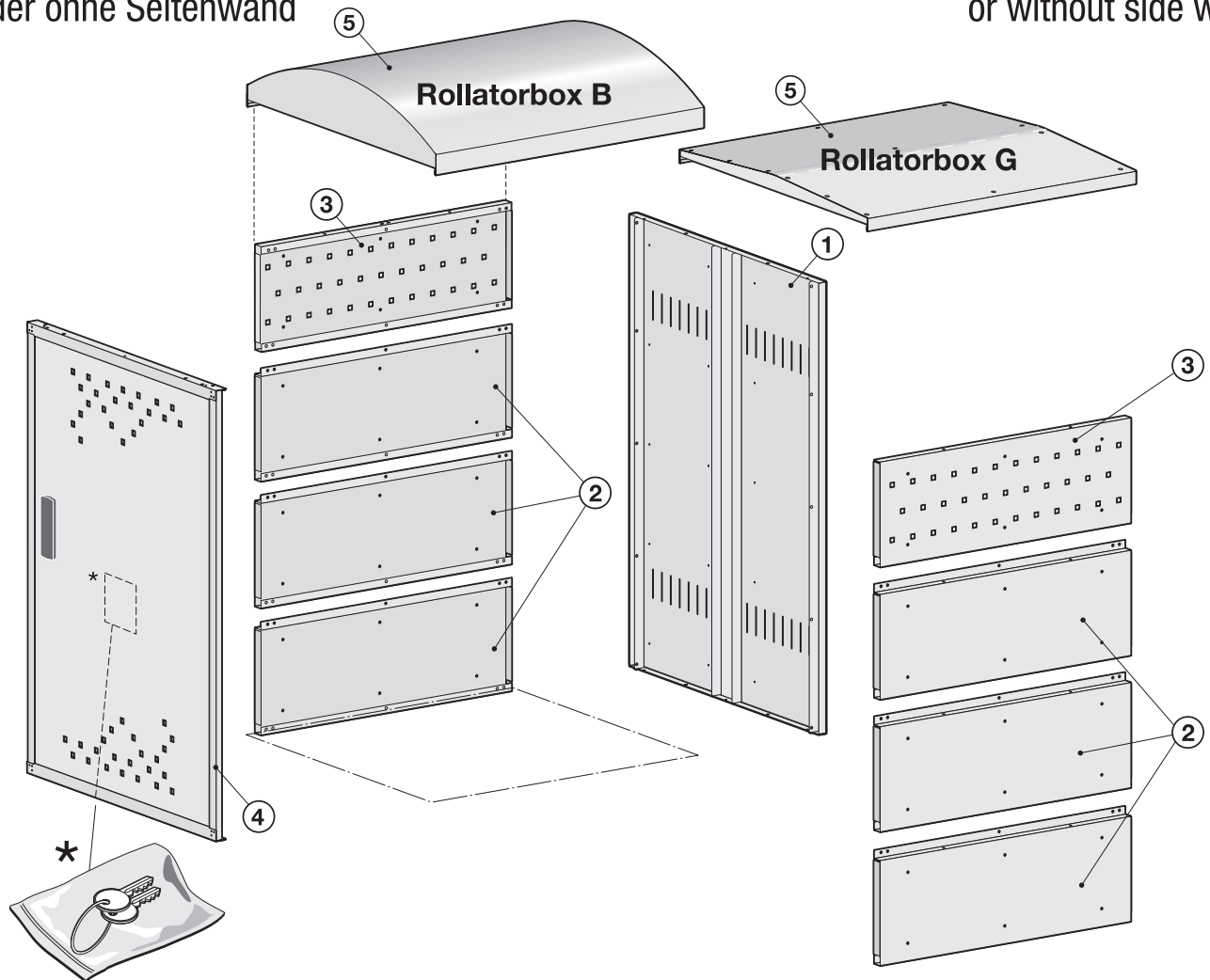
Rollator Box, complete

extendable with
or without side wall



 67 x 4,8x13 DIN 7981 C	 6 x 4 x 45 DIN 571	 6 x Ø 8	 2 x M8 x 20 DIN 933	 22 x 8,4 DIN 9021
------------------------------------------------------------------------------------------------------------------	--------------------------------------------------------------------------------------------------------------	--------------------------------------------------------------------------------------------------	-----------------------------------------------------------------------------------------------------------------	---------------------------------------------------------------------------------------------------------------

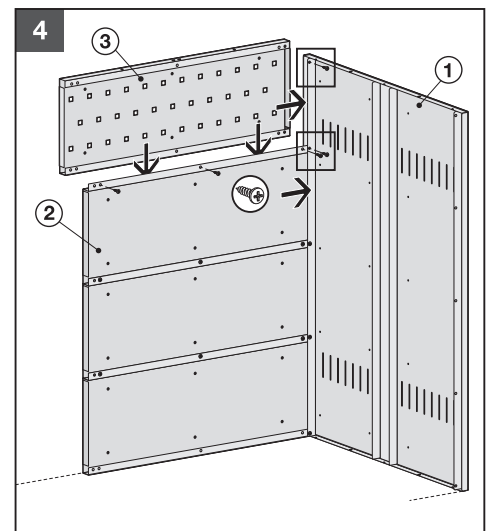
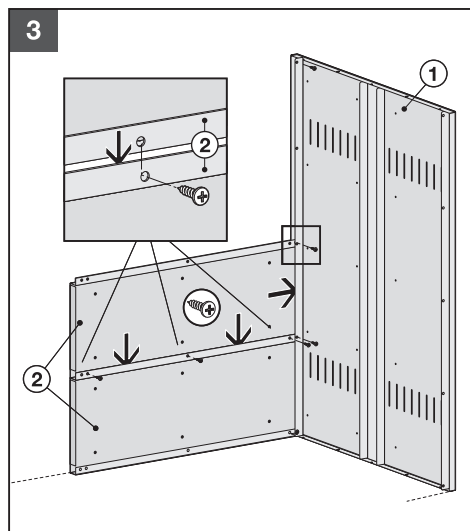
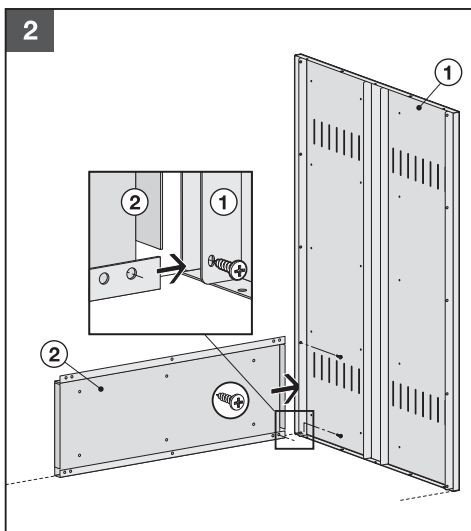

Falls zusätzlich ein **Anbausatz ohne Seitenwand** montiert werden soll, ändern sich die Montageschritte hinter **Bild 4**, siehe ab **Bild 6** der Montageanleitung für **Anbausatz ohne Seitenwand**. When adding an **extension element without side wall**, the assembly steps from **fig. 4** onwards are shown in the instructions for **extension elements without side wall** starting with **fig. 6**.

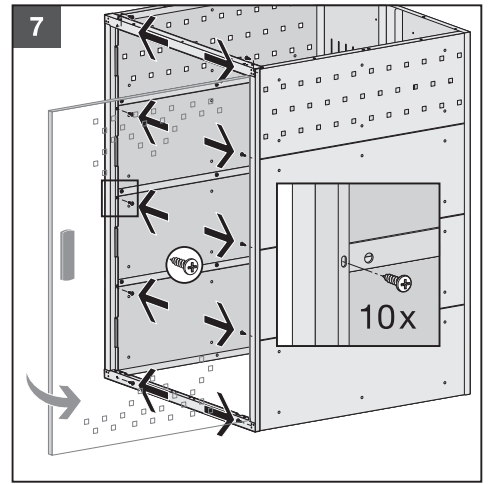
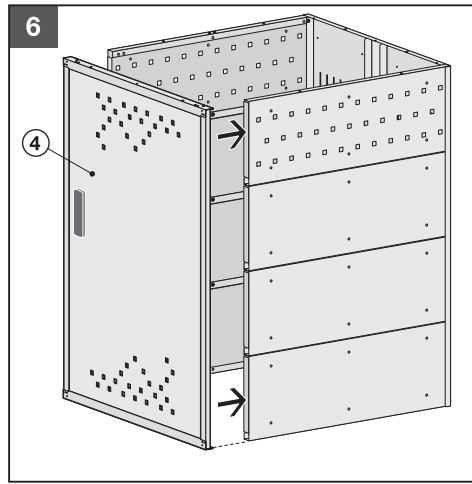
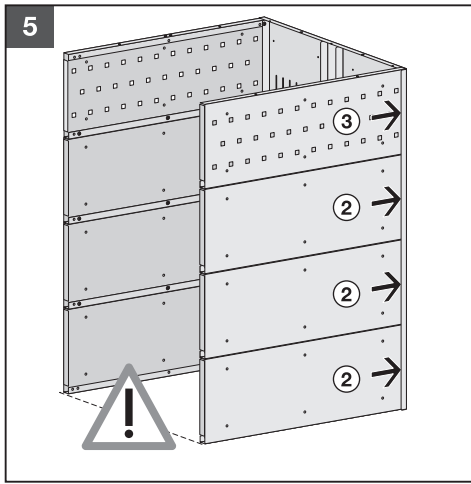

Veränderter Montageverlauf bei zusätzlicher Verwendung eines **Anbausatzes ohne Seitenwand** (siehe gesonderte Anleitung)

*Modified assembly steps when using an **extension element without side wall** (see separate instructions)*

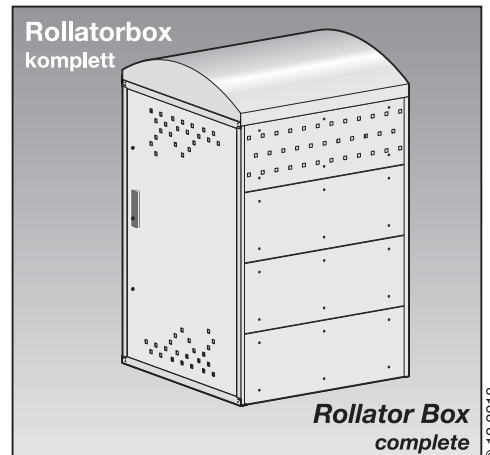
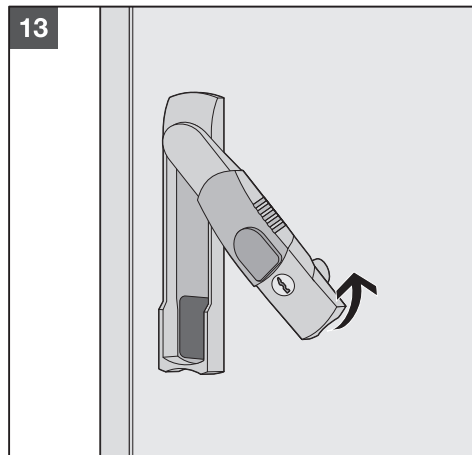
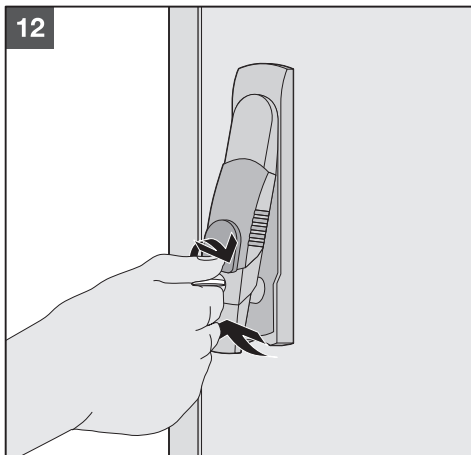
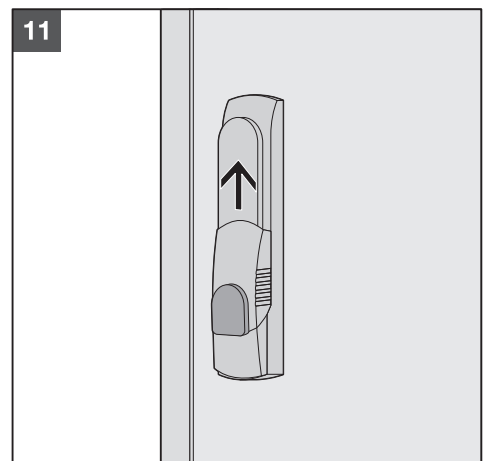
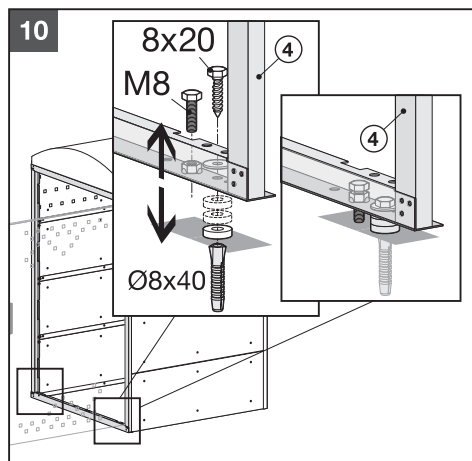
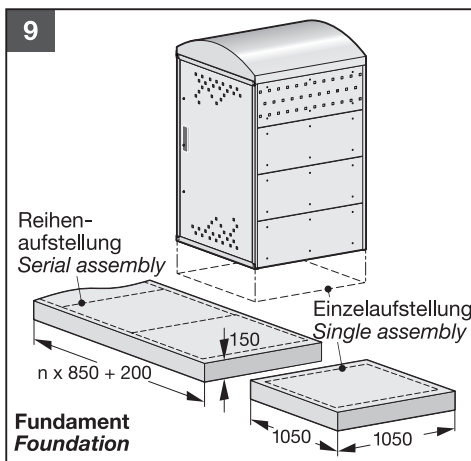
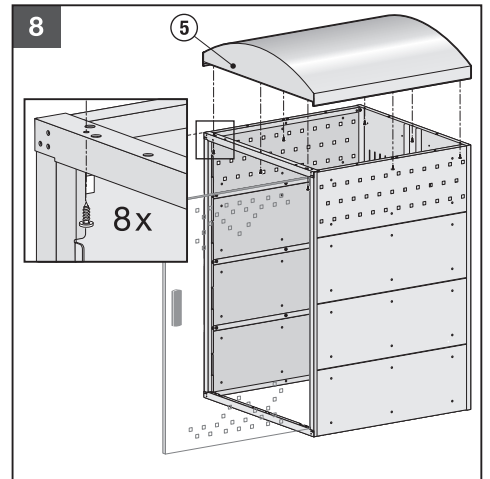
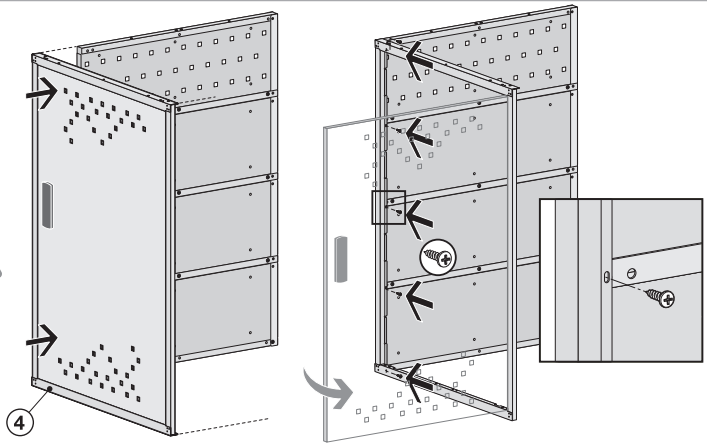

Falls zusätzlich ein **Anbausatz ohne Seitenwand** montiert werden soll, ändern sich die Montageschritte hinter **Bild 4**, siehe ab **Bild 6** der Montageanleitung für **Anbausatz ohne Seitenwand**. *When adding an **extension element without side wall**, the assembly steps from **fig. 4** onwards are shown in the instructions for **extension elements without side wall** starting with **fig. 6**.*